

→ THE MOUTHPIECE

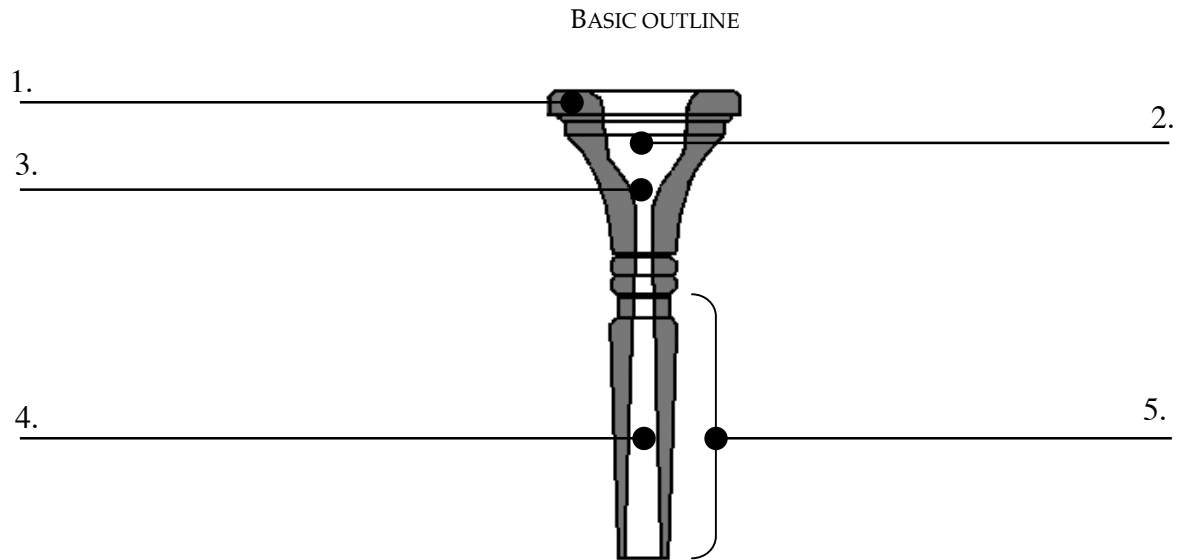

1. RIM

2. CUP

3. THROAT

4. BACKBORE

5. SHANK

→ MOUTHPIECES (CONT.)

- MOUTHPIECE MANUFACTURERS

- ALLOYS

- RECOMMEND TUBA MOUTHPIECE

- RECOMMEND EUPHONIUM MOUTHPIECE

- RECOMMEND TROMBONE MOUTHPIECE